

LEKTRO

1190 S.E. Flightline Drive, Warrenton, Oregon 97146-9692
1-800-535-8767 • 503-861-2288 • Fax 503-861-2283
E-mail: sales@lektro.com
http://www.lektro.com

Model AP8360 AIRCRAFT TOWING VEHICLE FOR AIRCRAFT UP TO 15,000 lbs. / 6,804 KG

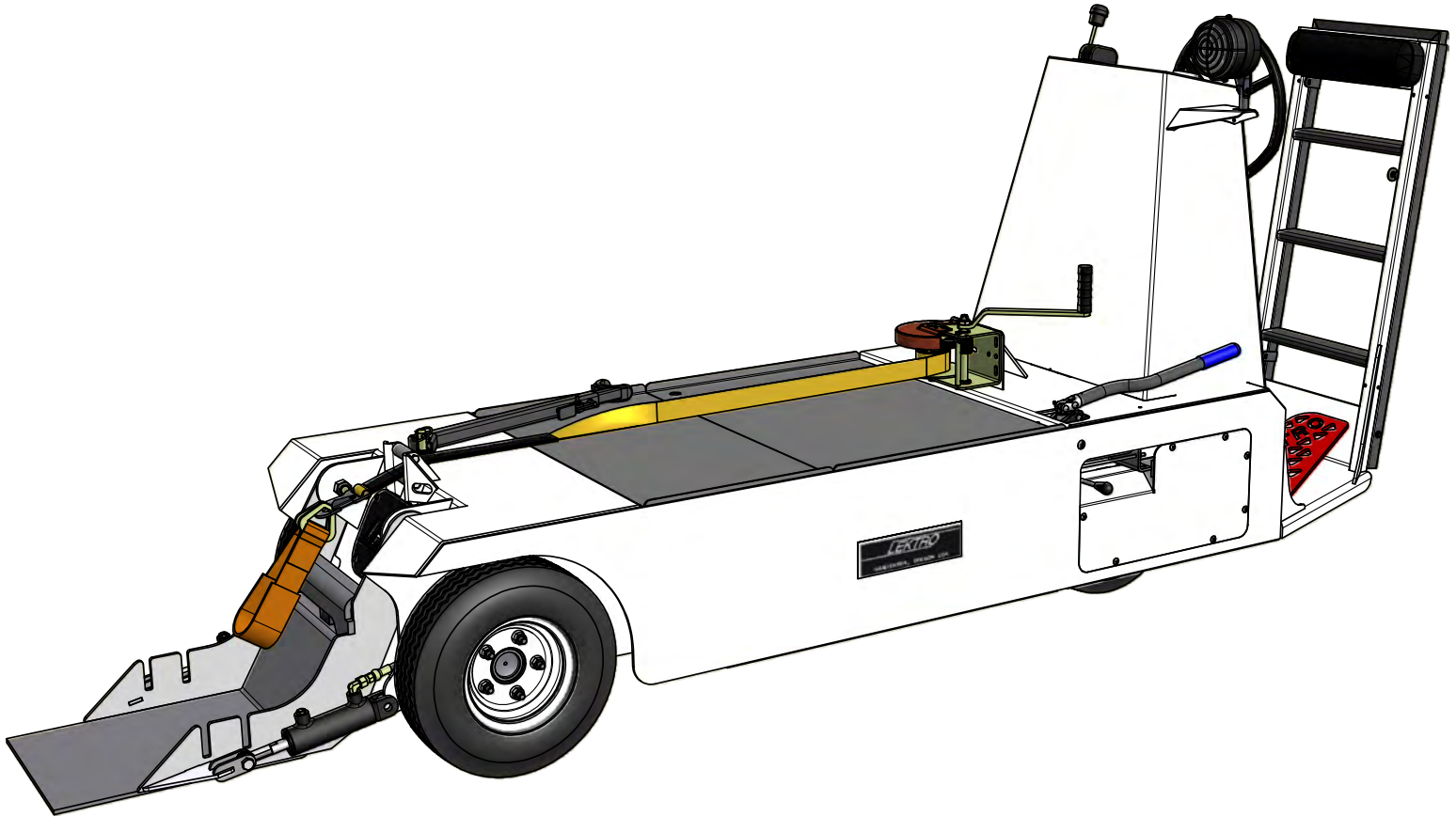

AP8360 FEATURES:

Vehicle Drive: 2.0 HP, 36 VDC Traction Motor mated with High-Efficiency Helical Gear Dana Axle Assembly.

Motor Speed Control: Curtis SEPEX Electronic Speed Control with Reverse Direction Braking. On-board Diagnostics, optional.

Batteries: Six 6 VDC, 220 AMP-HR Batteries (20 hr rate), wired in series.

G.P.U.: Built-in 12/24/30 VDC / 600 CCA Motive/GPU Batteries, optional. Built-in Heavy Duty 12/24/28 VDC / 1175 CCA Motive/GPU battery and Charging System also optional.

Motive Battery Charger: External Fully Automatic 25 AMP DC / 110 VAC / 60 Hz / 1-PH Charger. 230 VAC / 50 Hz, optional.

Nose Gear Lift Cradle: Patented Universal Hand Pump Hydraulic Nose Gear Lift Cradle capable of handling dual and single wheel aircraft. A Hold Down Provision for light-nosed aircraft and Wheel Faring Package, optional.

Winch: Single-Speed Hand Winch. Winch and Strut Straps included.

Steering: Automotive-type Wheel coupled to an Automotive Gear Box resulting in very responsive steering action.

Service Brakes: Foot Operated Drum-Type Service Brakes.

Parking Brake: Foot activated, spring-applied, pedal released Deadman Parking Brake.

Drive Tires: 4.80/4.00 x 8 6-ply Pneumatic Highway Tread. Traction Tread, Poly-Foam and Chains, optional.

Steer Tires: Dual 4.80/4.00 x 8 6-ply Pneumatic Highway Tread. Poly-Foam, optional.

Lighting: Single 360° Rotating Spotlight, optional.

Extension Ladder: Step Ladder attached to operator's back rest, optional.

Operator's Compartment: Single-person configuration, Stand-Up Operation.

Construction: Welded Steel Plate and Polymers preserved by Primer and Automotive High-Gloss Red or White Enamel Paint with special protective Polyurethane Coating to prevent rust, scratches and corrosion. Custom colors, optional.

SPECIFICATIONS:

Length.....	131.75 in / 334.9 cm
Width	32.5 in / 82.2 cm
Height (at top of steering wheel).....	49.75 in / 126.1 cm
Turning Radius	106.0 in / 269.2 cm
Wheel Base	62.25 in / 158.0 cm
Vehicle Speed, Empty	5 mph / 8 kph
Vehicle Speed, Loaded	3.6 mph / 5.8 kph
**Lift Cradle Capacity	1,500 lbs / 680 kg
Nose Gear Cradle Lifting Height.....	9 in / 23 cm
Ground Clearance	4.8 in / 12.2 cm
Chassis Weight w/ Batteries & Charger	1375 lbs / 623.7 kg

**Lift Capacity is calculated with 14 in / 35.6 cm diameter aircraft tire in lift cradle. Aircraft tire centerline at 17.6 in / 44.7 cm from drive tire centerline.

ADDITIONAL OPTIONS:

Draw Bar Pin and Specialized Aircraft Towing Adapters available (consult factory). Illustration may show some optional equipment.

*LEKTRO reserves the right to make changes and improvements in products and specifications without notice or obligation.

PATENT Nos. 5,151,003 / 5,302,075 / 9,067,691.

Other Patents Pending.

LEKTRO

1190 S.E. Flightline Drive, Warrenton, Oregon 97146-9692
1-800-535-8767 • 503-861-2288 • Fax 503-861-2283
E-mail: sales@lektro.com
http://www.lektro.com

Model **AP8360** AIRCRAFT TOWING VEHICLE FOR AIRCRAFT UP TO 15,000 lbs. /6,804 KG

